



Beyond modular systems: Standardized specialty

For years, forklift trucks outfitted with IMS Gear's planetary gearboxes have been operating quietly and efficiently in large industrial warehouses around the world. Our gearboxes are a vital component at the heart of the electromechanical steering system of material handling equipment. The latest generation of our PM 80 LN-SD gearbox is now available. It comes in a dynamic, new configuration, composed of proven components from our IMS.baseline

and IMS.techline product lines, combined with specially designed components from the IMS.SDline. The performance of this new gearbox extends far beyond the limitations of our modular system. Without the cost and lead-time required for customer-specific specialization, we've designed a gearbox which readily conforms to exacting requirements regarding torque, noise emission and installation space.

For almost two decades, leading manufacturers of industrial trucks have been relying on planetary gears from IMS Gear to implement safe and quiet steering. The capability to reliably transmit great forces in small spaces makes planetary gears ideal for this application. In the past, IMS Gear implemented user-specific requirements to produce these gearboxes, factoring in variables such as limitations on installation space and required torque strength. This led us to developing two gear variants with different diameters, for this application.

Over the years, our gearboxes for this application have continuously improved by taking advantage of innovation within our modular system. “In 2001, the declared goal was to reduce the noise level”, stated application engineer Andreas Sigwart describing the initiative for ground-breaking further development. The need for a better solution was triggered by changes to the drive system of industrial trucks, particularly that of forklift trucks. Much quieter, battery-powered electric drives have replaced combustion engines powered by diesel or compressed gas.

Developing a planetary gearbox specifically designed for optimized noise emissions would have taken a long time, large investment and come with corresponding technical risks. However, using a helical geared input stage from IMS Gear’s modular system, allowed us to eliminate the need for developing a completely a new product.

New ways beyond the modular system:

Special mix of three design sizes

The helical geared solution from IMS.techline has been in production for more than 10 years.

Despite its long history of reliable service, we further optimized the design of this gear to improve its performance. This updated version is now available in the new PM 80 LN-SD of the IMS.SDline. It offers higher continuous torques, increased overload torque resistance, longer service life and further improvement of the noise characteristics. „All of this had to be implemented within a smaller installation space in order to enable compatibility with as many steering systems as possible“, Mr. Sigwart explains.

To find a solution, IMS Gear tapped into the magic box of IMS.SDline. As a result, the product designers advanced the modular system strategy a step further. The combination of various series within a gearbox, enhanced by new SDline-components, led to a technological breakthrough driving the product well beyond the performance parameters of the existing, modular system.

Here are the highlights of the new design:

- The helical geared input stage of the PM 81 LN ensures smooth and quiet operation.
- The bearing pins of the IMS.techline planetary carriers have been radially flattened on both sides for this application. This creates a new lubrication groove that significantly increases the service life of the gear.
- Instead of a bolted axial joint with a housing diameter of 105 mm, IMS Gear uses a new radially shortened single-piece housing from

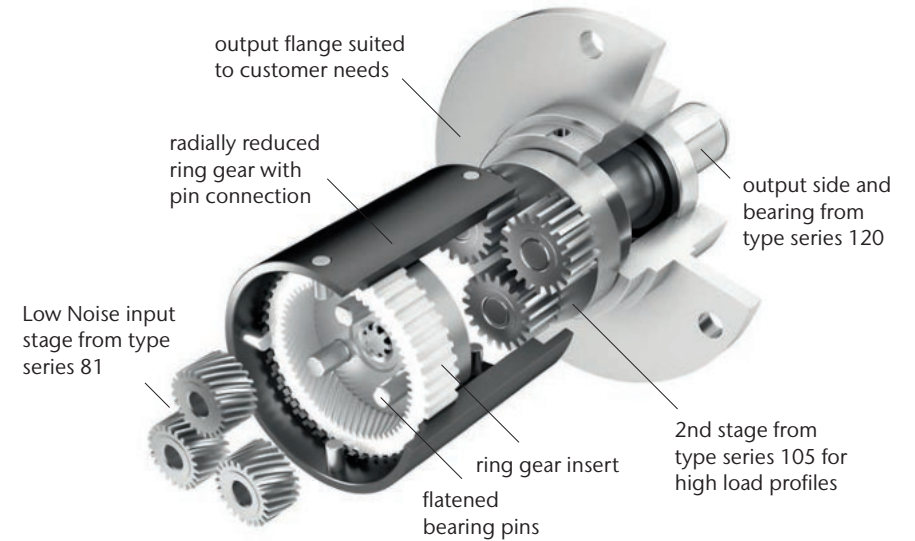

Sectional model of the PM 80 LN-SD

the IMS.SDline with a diameter of 80 mm. Apart from the reduced installation space, this also makes the bearing flange obsolete as it can now be integrated.

- Installing the gear and motor does not involve threaded bolts but the gearbox is radially pinned to the motor instead. This type of joint prevents twisting of the motor relative to the gearbox, which is increasingly important in view of higher torques.
- A special helical geared insert from the SDline serves as a ring gear in the first stage. The insert is toothed on the outside to create a positive engagement with the toothed housing of the second stage, hence preventing twisting.
- In the output stage, planet gears from IMS.baseline of design size PM 105 trans-

mit the high torques and can absorb brief dynamic peak loads. These planet gears have already made a name for themselves in various forklift truck power steering projects with high load requirements.

- On the customizable output side, IMS Gear uses ball bearings and the PM 120 output shaft from the IMS.baseline in standard configuration. These two components can withstand the strong radial forces acting on the output. The forces are generated by events such as unintentional contact of the forklift wheel with kerbs.

The result of these various enhancements is an intelligently designed IMS.SDline gearbox comprised of the ideal components from IMS.baseline and IMS.techline, plus purpose-designed parts to optimize performance and lessen noise.



Example for the electromechanical steering of forklift trucks

Modular design principle enables further improvements

Heinz Gert Hagedorn, Vice President Sales & Engineering Planetary Gears, identifies further technical potential for performance improvements within the modular system: “Further development of the modular system as an ongoing process will continue to provide new options”, citing the choice of using oil instead of grease lubrication as an example. He states that “transmission of significantly higher power as well as longer service life are conceivable within the required installation space. We consider the modular system an outstanding opportunity to implement tailor-made planetary gears for customer-specific applications.” This enables fast and economical development of solutions with minimized technical risks.

“The new IMS.SDline offers options in cases that go beyond basic requirements.” This is particularly important in safety-related applications such as the ,steer by wire‘ system of the electromechanical steering for forklift trucks.

Conclusion

The possibilities of using IMS Gear’s modular system extend far beyond the limits of the respective product lines or gear design sizes. “Beyond the modular system” refers to a smart combination of the various product lines across different design sizes. This results in specialized standard gearboxes.